

Noa

HTV®
Technology for Stowage



Noa 20/30



NEW NOA AUTOMATIC SHACKLE

The NOA automatic shackle is a load-lifting accessory that has been designed to automatically couple to and uncouple from loads from a distance in response to radio signals. It is easy to install and can be adapted to work with any type of lifting machinery capable of supporting and lifting such loads.

The lifting capacity of the NOA automatic shackle depends on the model used, its configuration and the way that it is used.

The NOA automatic shackle comes in different models which are all equipped for use with cranes. The different models: single block, revolving eye bolt and fixed eye bolt, all offer different capacities (consult table of models).

The load is fixed using the pin which the NOA device activates pneumatically.

The NOA shackle has luminous signalling that informs the operator of the position of the pin (open-closed). This prevents the risk of the equipment being used when the pin is in an intermediate position or when its position is not known to the operator.

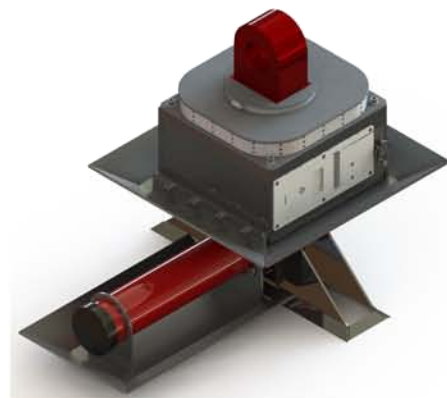

BASIC MODELS

043M00022
043M00034



SINGLE BLOCK

043M00030
043M00031



HBM

043M00032
043M00033



EYE BOLT



NOA - 043M00022 / 043M00034

043M00022	043M00034
<ul style="list-style-type: none">• Capacity: 10 t, 20 t	<ul style="list-style-type: none">• Capacity: 10 t, 20 t, 25 t
<ul style="list-style-type: none">• Pin: Ø40	<ul style="list-style-type: none">• Pin: Ø50
SINGLE BLOCK SHACKLE	

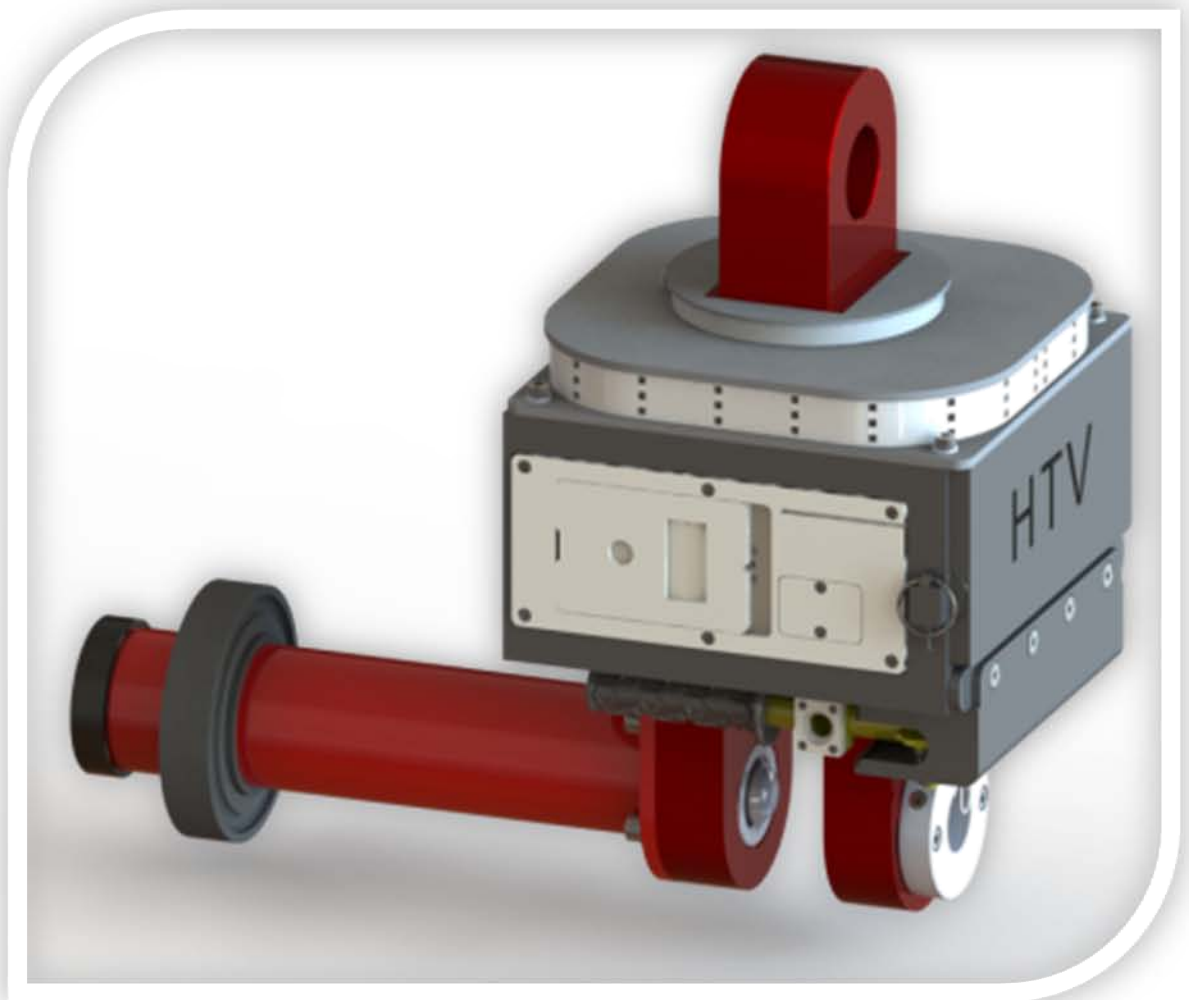



NOA – 043M00030 / 043M00031

043M00030	043M00031
<ul style="list-style-type: none">• Capacity: 10 t	<ul style="list-style-type: none">• Capacity: 10 t
<ul style="list-style-type: none">• Pin: Ø40	<ul style="list-style-type: none">• Pin: Ø50
HBM SHACKLE	









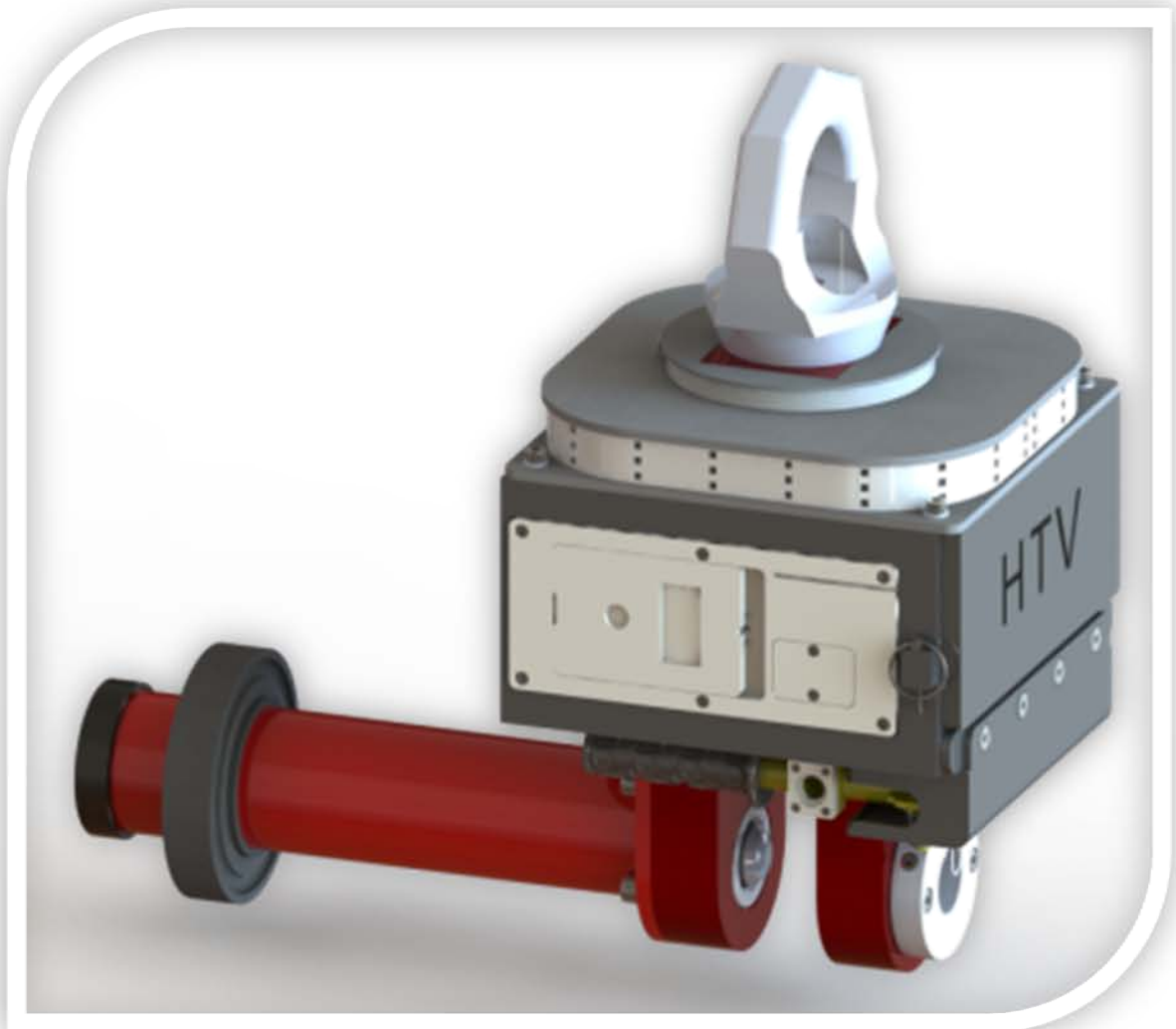

NOA – 043M00032 / 043M00033

043M00032	043M00033
<ul style="list-style-type: none">• Capacity: 10 t, 20 t	<ul style="list-style-type: none">• Capacity: 10 t, 20 t, 25 t, 30 t
<ul style="list-style-type: none">• Pin: Ø40	<ul style="list-style-type: none">• Pin: Ø50
EYE BOLT SHACKLE	





RANGE OF NOA ACCESSORIES

ACCESSORY		DESCRIPTION	IMAGE
HANDLEBAR		Folding handlebar with built-in controls. Note: Not compatible with heat dissipators	
TOOL FOR EXTRACTING BUSHING		Tool for installing and dismantling the bushing around the pin	
MAINTENANCE SUPPORT		Support to facilitate the storage and maintenance of the NOA	
BATTERY BRIEFCASE		Briefcase to facilitate the transportation and charging of the batteries. Capacity to simultaneously carry and charge 6 or 12 batteries and chargers.	
HEAT DISSIPATORS	DISSIPATOR BOX	Heat dissipators to protect the NOA during the coupling of elements that are at high temperatures. Note: Not compatible with the handlebar	
	CYLINDER DISSIPATOR		
POSITIONERS	HANDLES	Positioner to facilitate coupling. Note: Possibility of adding illumination to facilitate visibility in the coupling area.	
	LARGE RINGS	Positioner with partial lateral opening to facilitate the coupling of rings with exteriors of up to Ø 500 mm.	

HTV[®]

Technology for Stowage

MODEL EXAMPLES AND STANDARD REFERENCES

BASIC MODEL	SERIES CHARACTERISTICS			ACCESSORIES			REFERENCE
	LOAD CELL / STRAIN TRANSDUCER	SHACKLE	Ø PIN (mm)	HANDLEBAR	HEAT DISSIPATOR + POSITIONER		
					HANDLES	RINGS	
043M00022	-	SINGLE BLOCK	40	•	-	-	043M00022-0-M-00
043M00022	-	SINGLE BLOCK	40	-	•	-	043M00022-0-0-DO
043M00022	-	SINGLE BLOCK	40	-	-	•	043M00022-0-0-DA
043M00022	•	SINGLE BLOCK	40	•	-	-	043M00022-P-M-00
043M00022	•	SINGLE BLOCK	40	-	•	-	043M00022-P-0-DO
043M00022	•	SINGLE BLOCK	40	-	-	•	043M00022-P-0-DA
043M00030	•	HBM	40	•	-	-	043M00030-P-M-00
043M00030	•	HBM	40	-	•	-	043M00030-P-0-DO
043M00030	•	HBM	40	-	-	•	043M00030-P-0-DA
043M00031	•	HBM	50	•	-	-	043M00031-P-M-00
043M00031	•	HBM	50	-	•	-	043M00031-P-0-DO
043M00031	•	HBM	50	-	-	•	043M00031-P-0-DA
043M00032	-	EYE BOLT	40	•	-	-	043M00032-0-M-00
043M00032	-	EYE BOLT	40	-	•	-	043M00032-0-0-DO
043M00032	-	EYE BOLT	40	-	-	•	043M00032-0-0-DA
043M00032	•	EYE BOLT	40	•	-	-	043M00032-P-M-00
043M00032	•	EYE BOLT	40	-	•	-	043M00032-P-0-DO
043M00032	•	EYE BOLT	40	-	-	•	043M00032-P-0-DA
043M00033	-	EYE BOLT	50	•	-	-	043M00033-0-M-00
043M00033	-	EYE BOLT	50	-	•	-	043M00033-0-0-DO
043M00033	-	EYE BOLT	50	-	-	•	043M00033-0-0-DA
043M00033	•	EYE BOLT	50	•	-	-	043M00033-P-M-00
043M00033	•	EYE BOLT	50	-	•	-	043M00033-P-0-DO
043M00033	•	EYE BOLT	50	-	-	•	043M00033-P-0-DA
043M00034	-	SINGLE BLOCK	50	•	-	-	043M00034-0-M-00
043M00034	-	SINGLE BLOCK	50	-	•	-	043M00034-0-0-DO
043M00034	-	SINGLE BLOCK	50	-	-	•	043M00034-0-0-DA
043M00034	•	SINGLE BLOCK	50	•	-	-	043M00034-P-M-00
043M00034	•	SINGLE BLOCK	50	-	•	-	043M00034-P-0-DO
043M00034	•	SINGLE BLOCK	50	-	-	•	043M00034-P-0-DA

0 = NOT INCLUDED. P = LOAD CELL / STRAIN TRANSDUCER M = HANDLEBAR DO = HANDLE DISSIPATOR. DA = RING DISSIPATOR



CODES FOR MAKING ORDERS

Apart from the standard models, it is also possible to order other available options:

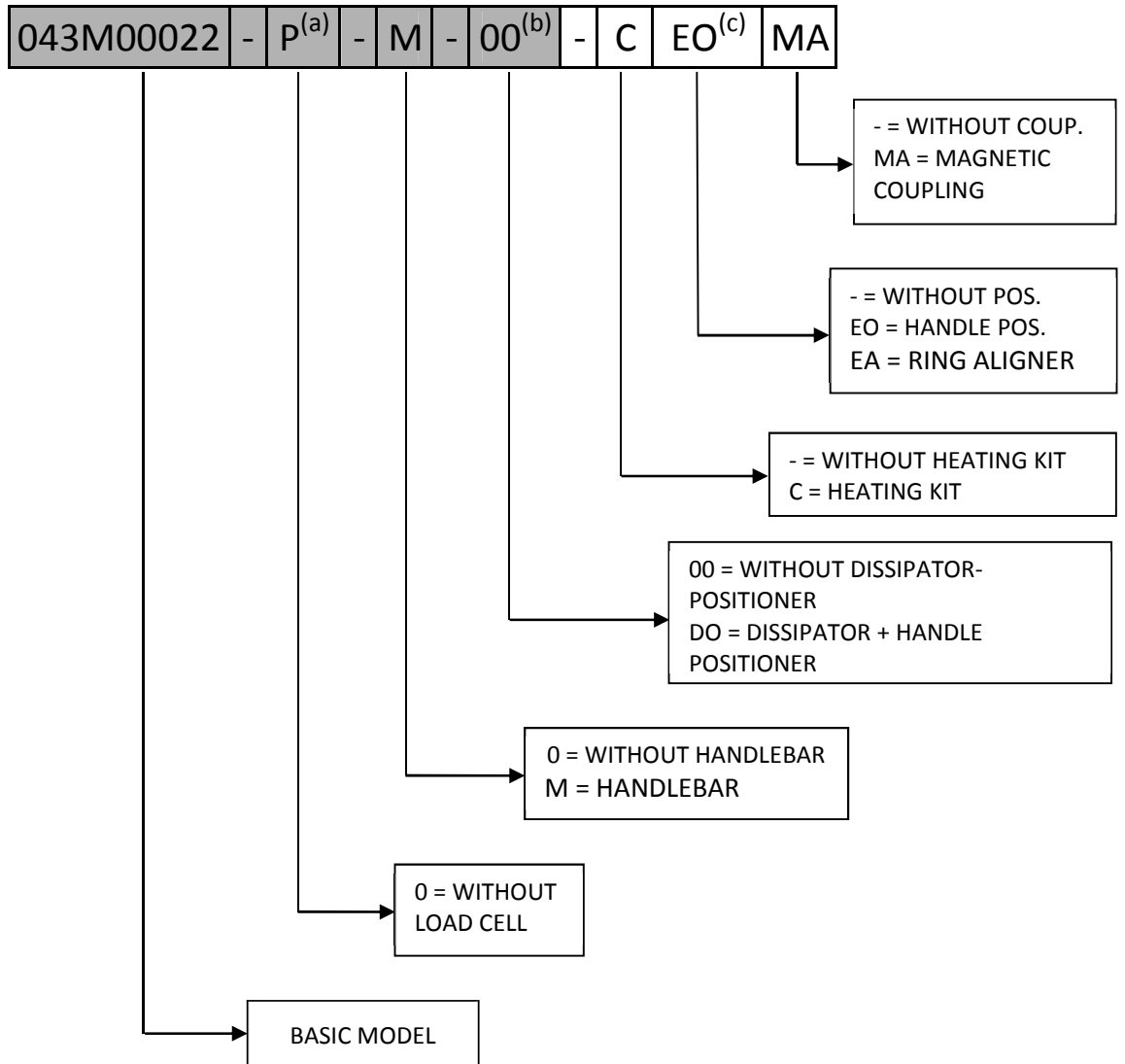

- (A) THE MODELS WITH HBM SHACKLES ALWAYS HAVE LOAD CELLS INCORPORATED.
 (B) THE HANDLEBAR OPTION IS INCOMPATIBLE WITH THE HEAT DISSIPATOR OPTION.
 (C) THE HEAT DISSIPATOR OPTION INCLUDES THE POSITIONER.

SECURITY FACTOR TABLE

BASIC MODEL	FDS			
	10 T	20 T	25 T	30 T
043M00022	8	4	-	-
043M00030	4.5	-	-	-
043M00031	4.5	-	-	-
043M00032	8	4	-	-
043M00033	12	6	4.8	4
043M00034	10	5	4	-



RANGE OF WORKING TEMPERATURES

STANDARD TEMPERATURE RANGE:

Temperature	-5 °C to 60 °C	All the standard models
-------------	----------------	-------------------------

EXTREMELY COLD TEMPERATURES:

Temperature	to -20 °C	This requires the heating option (c)
-------------	-----------	--------------------------------------

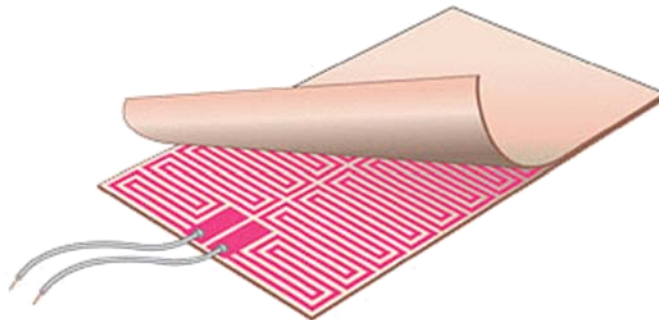

EXTREMELY HIGH TEMPERATURES:

Temperature	60 °C to 80 °C	This requires the thermal dissipator option (DA-DO)
-------------	----------------	---

The NOA shackle has the option of carrying heat dissipators for working in areas exposed to extremely high temperatures. The following diagram has been produced with the aim of providing an initial idea about how this works. By introducing the temperature radiating from the heat source and using the distance curve, which will be the separation between the NOA work point and the surface of the heat source, it is possible to obtain the maximum time during which the NOA can be exposed to heat without its internal temperature rising above 60 °C (which is considered the safety limit for the NOA mechanisms and their electronic systems).

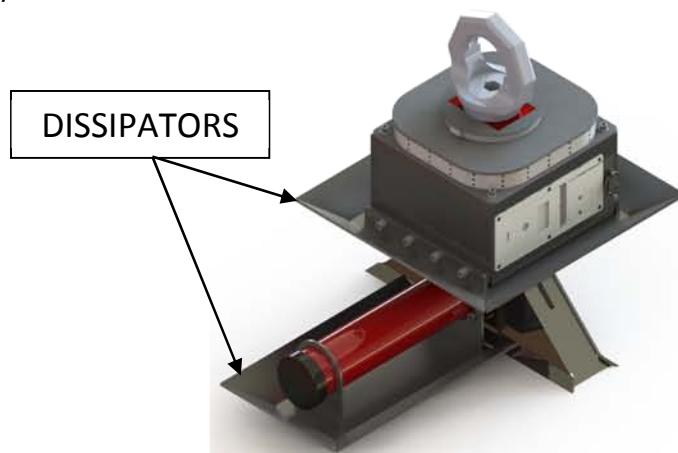

**GENERAL SCHEME OF EXPOSURE TO
EXTREMELY HIGH TEMPERATURES**

- $A \sim 0.35 \text{ m}^2$ (NOA dissipator surface)
- $m_{\text{box}} = 20 \text{ kg}$ | St-37

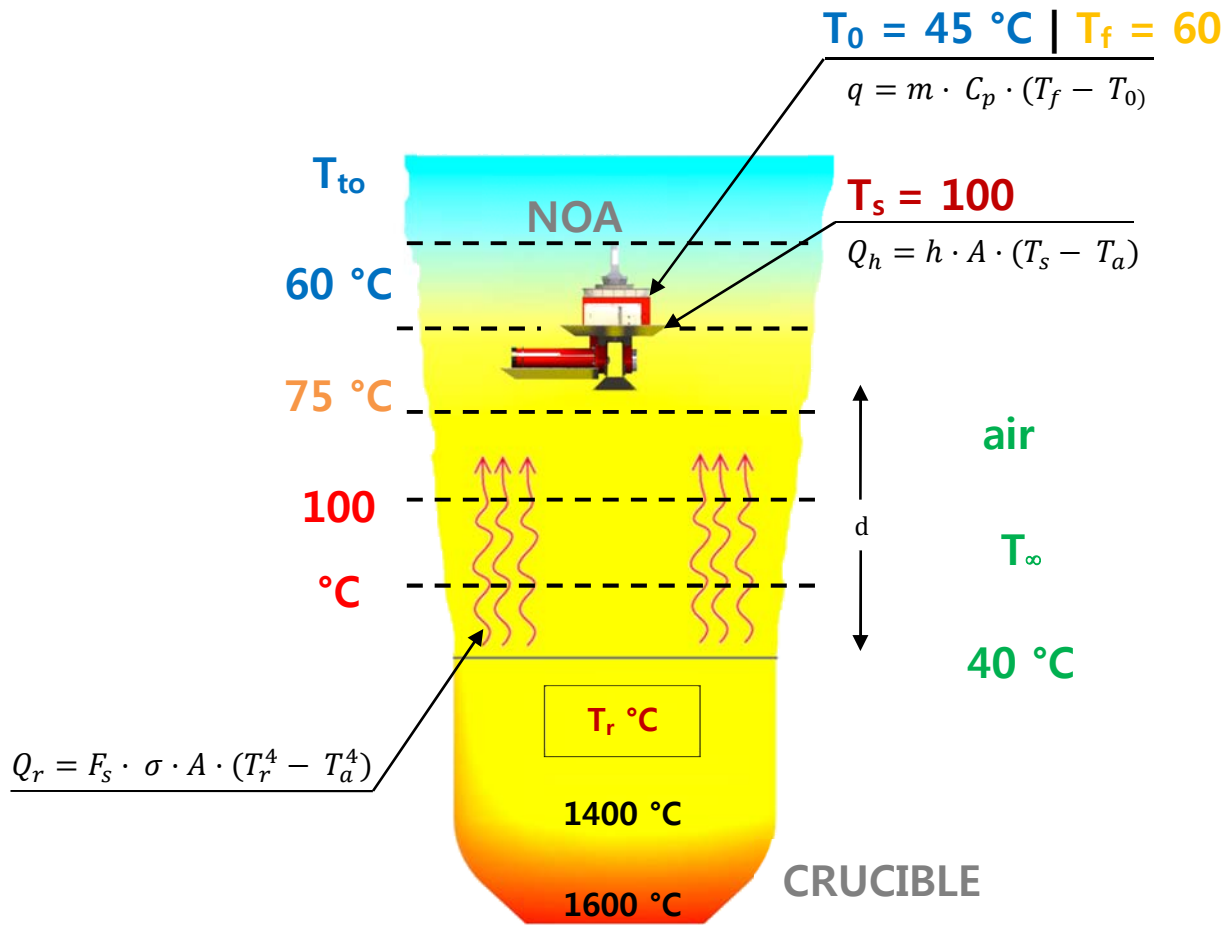

Figure 1. Establishing the most extreme conditions that can be encountered during the loading and transportation of the crucible melting pot.

NOMENCLATURE

A = area equivalent to the horizontal surface of both dissipators, piston + box.

m_{box} = metallic mass of the NOA box.

T_0 = temperature of the metallic part of the box at the beginning of the manoeuvre.

T_f = maximum permitted temperature that the metallic part of the box can reach.

T_a = environmental temperature according to the area.

T_s = surface temperature of the dissipators.

T_r = temperature on the surface of the heat focus.

d = distance between the NOA and the surface of the heat source.

Q_r = heat flow by radiation.

Q_h = heat flow by convection.

q = calorific energy that the NOA box can store for the thermal gradient ($T_f - T_0$).



Maximum time during which the NOA can be exposed to high temperatures without its internal temperature exceeding 60 °C

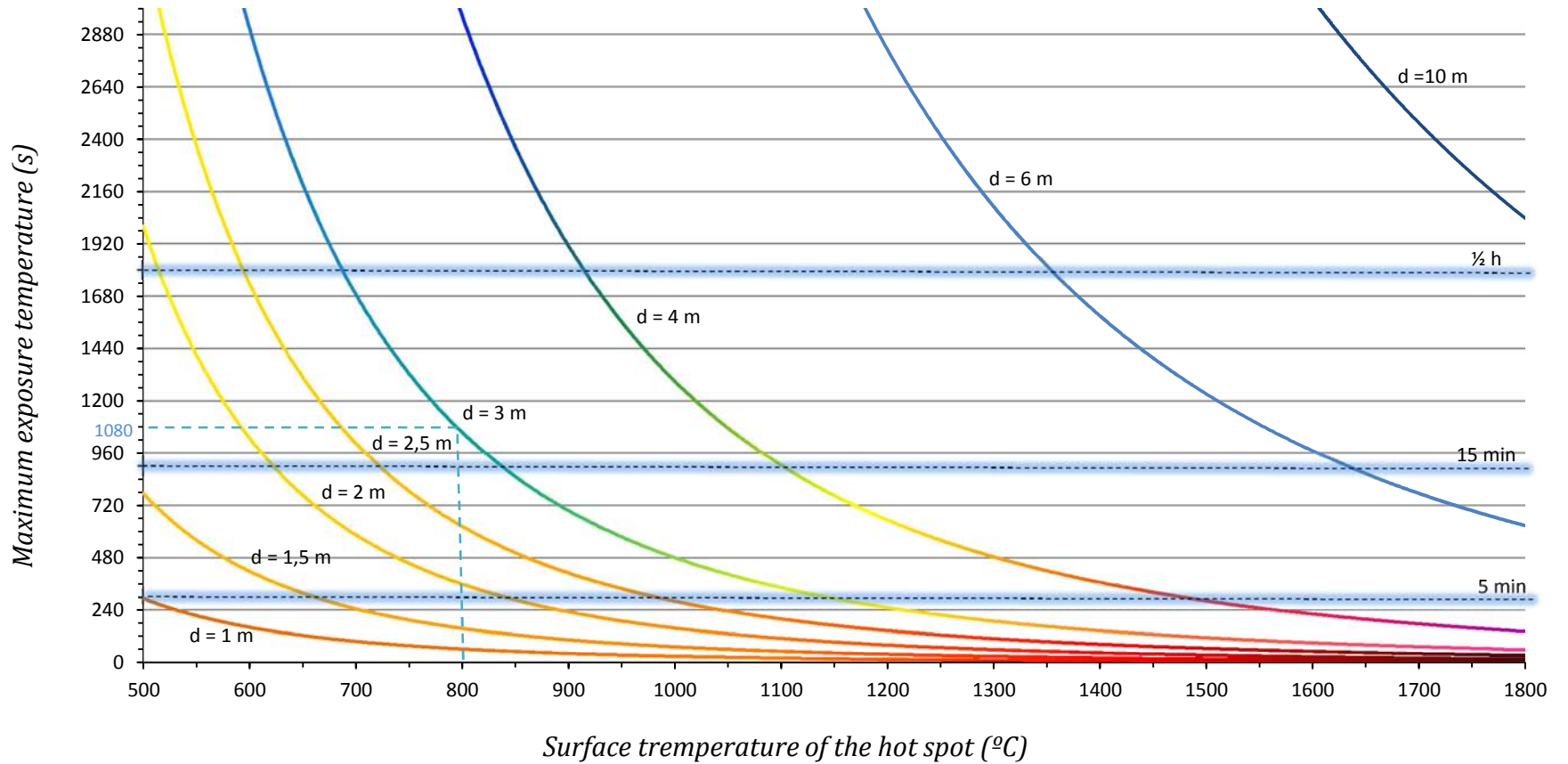

e.g.: If the NOA must transport a melting pot containing a liquid with a surface temperature of 800 °C and there is a distance of 3 m between the NOA and the surface, then d = a distance of 3 m → maximum_{temperature} = 1080 s ≡ 18 min. After every 18 min of continuous operation the NOA box will need to be cool t below 45 °C.

- This graph is for general orientation.
- Each specific case could require the in situ calculation of certain values and parameters.
- Maximum_{temperature} of the box = 60 °C. If exceeded, the electronic and mechanical components could be damaged.



OPTION OF NOA WITH HEAT DISSIPATORS

043M00022-0-0-DO

043M00022-P-0-DO

043M00034-0-0-DO

043M00034-P-0-DO

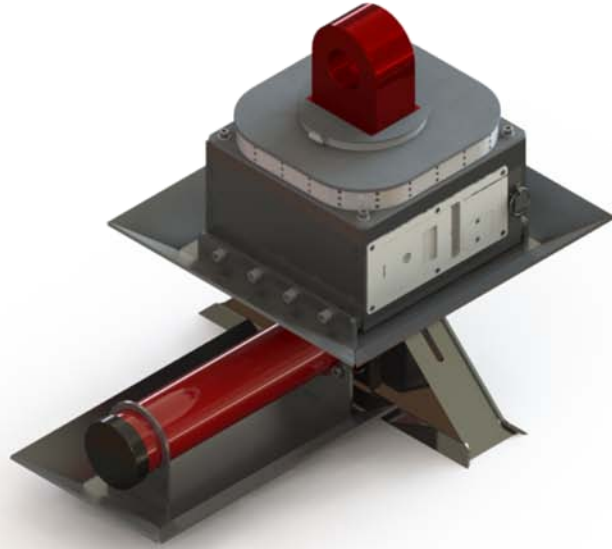

043M00022-0-0-DA

043M00022-P-0-DA

043M00034-0-0-DA

043M00034-P-0-DA

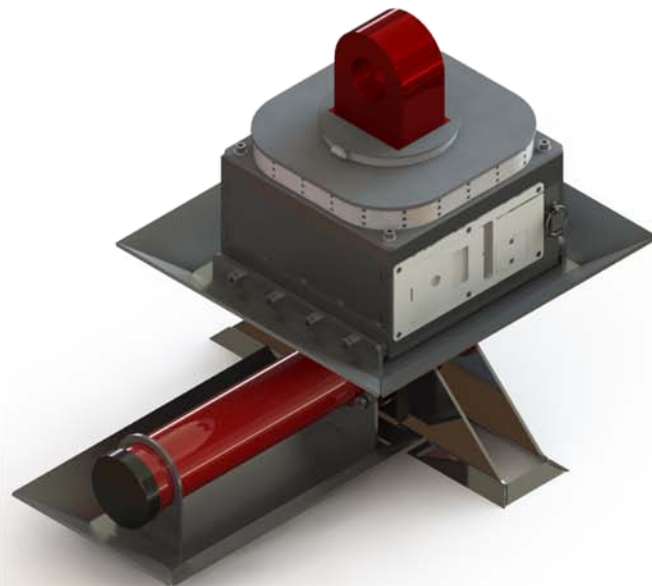



043M00030-P-0-DO
043M00031-P-0-DO

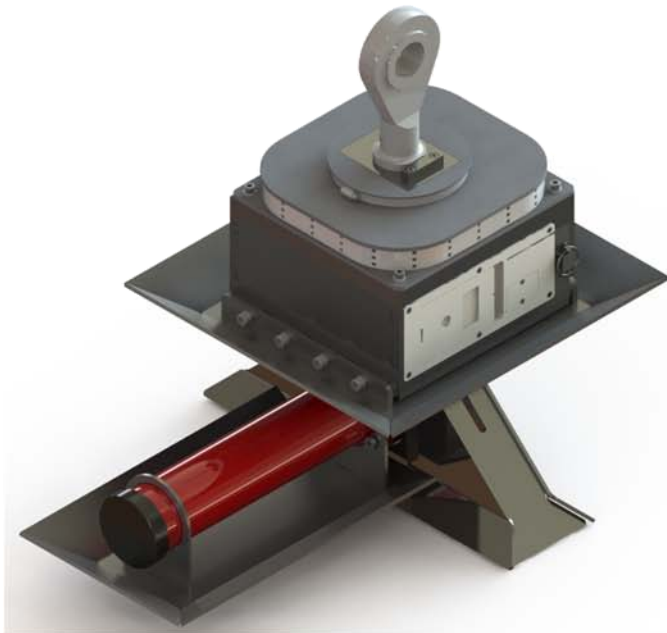

043M00030-P-0-DA
043M00031-P-0-DA

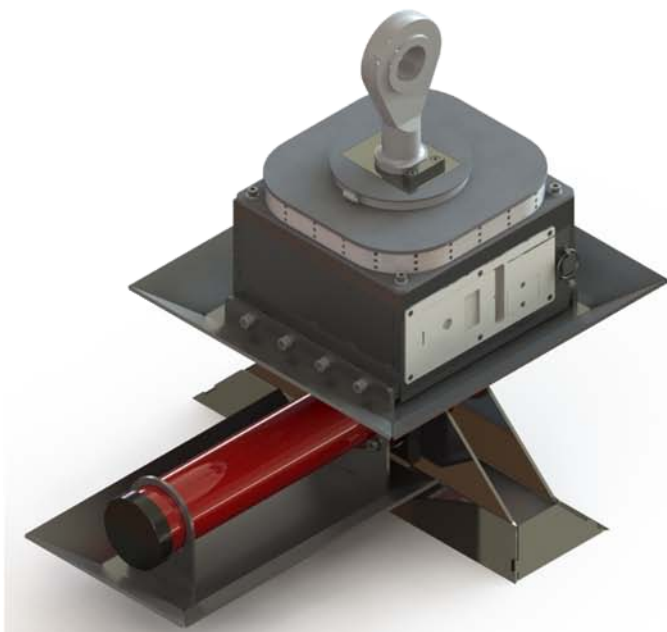



043M00032-0-0-DO
043M00032-P-0-DO
043M00033-0-0-DO
043M00033-P-0-DO

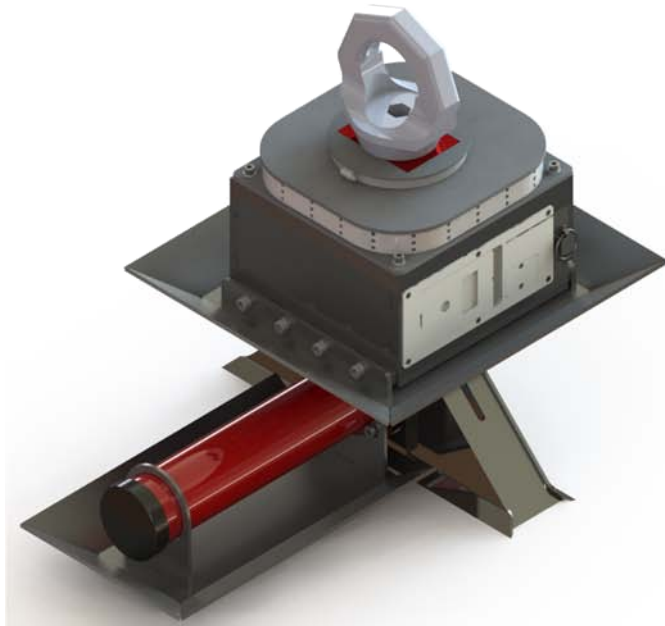

043M00032-0 -0-DA
043M00032-P -0-DA
043M00033-0 -0-DA
043M00033-P -0-DA

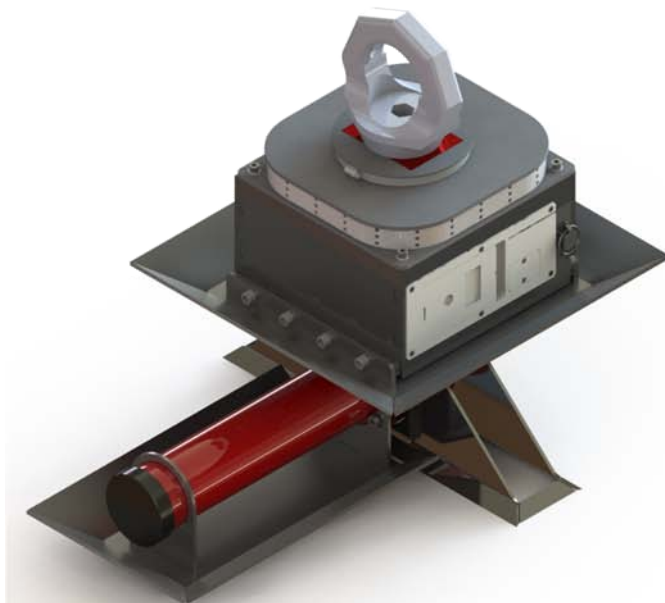



NEW NOA MAGNETIC HOOK

NOA now offers a new magnetic hook system, which automatically selects, positions and couples the ring. For further information, consult us at:

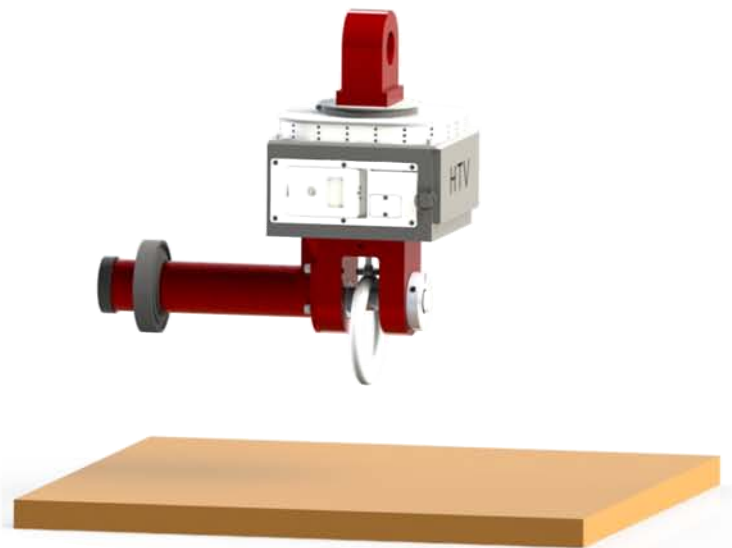
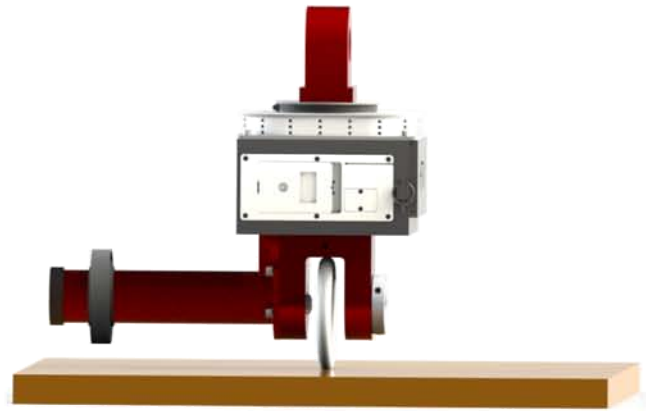



DESIGN, MANUFACTURING AND LOGISTICS

ED.30032016

POL.INDUSTRIAL AL-KANIS , NAVE 2, 25124, ROSSELLO, LLEIDA, SPAIN
TELEPHONE: 0034 973 730 059
MOBILE: 0034 601 350 299
INFO@HOOKSHTV.COM

ADMINISTRATION AND SYSTEMS

EDIF. PUERTA DE SANTANDER S/N, POLÍGONO DE RAOS, 39011, SANTANDER, CANTABRIA, ESPAÑA
TELEPHONE: 0034 942 356 394
CONTABILIDAD@HOOKSHTV.COM